



DESIGNING ELEVATORS



TRADITION HONESTY PROFESSIONALISM

Our company supplies and manages **elevators of all types, including escalators, travelators, cargo and disabled platforms** operating in various types of buildings.

In addition to the comprehensive services offered in vertical transport, we also provide service and maintenance of automatic doors, gates and gate systems.

From 2022, we are an **authorized distributor of PVE Elevators** for the Czech and Slovak Republics.

Our specialists are trained for the **design, installation and subsequent service** of this exclusive brand.

The following pages provide you with detailed information about PVE products.



A WORK OF ART POWERED BY AIR®





AROUND THE WORLD

Afghanistan · Albania · Algeria · Andorra · Angola · Antigua and Barbuda · Argentina · Armenia ·
Australia · Austria · Azerbaijan · Bahamas · Bahrain · Bangladesh · Barbados · Belarus · Belgium · Belize · Bolivia ·
Bosnia&Herzegovina · Brazil · Bulgaria · Côte d'Ivoire · Cambodia · Cameroon · Canada · Chile · China · Colombia · Costa
Rica · Croatia · Cyprus · Czech Republic · Denmark · Dominican Republic · Ecuador · Egypt · El Salvador · Finland ·
France · Georgia · Germany · Ghana · Greece · Guatemala · Honduras · Hungary · India · Indonesia · Iran · Iraq · Ireland ·
Israel · Italy · Jamaica · Japan · Jordan · Kenya · Kuwait · Latvia · Lebanon · Lithuania · Luxembourg · Malaysia · Malta ·
Mauritius · Mexico · Monaco · Mongolia · Morocco · Myanmar · Netherlands · New Zealand · Nicaragua · Nigeria ·
Norway · Oman · Pakistan · Panama · Paraguay · Peru · Philippines · Poland · Portugal · Qatar · Romania · Russia · Saint
Kitts and Nevis · Saint Lucia · Saint Vincent and the Grenadines · Saudi Arabia · Seychelles · Singapore · Slovakia ·
Slovenia · South Africa · South Korea · Spain · Sri Lanka · Suriname · Sweden · Switzerland · Thailand · Trinidad and
Tobago · Tunisia · Turkey · Uganda · Ukraine · United Arab Emirates · United Kingdom · United States of America ·
Uruguay · Venezuela · Vietnam

2	VÝTAHY PRAHA GROUP
7	PVE COMPANY
8	OUR TECHNOLOGY
10	OUR VALUES
15	MODELS
16	CUSTOMIZATION
19	CONFIGURATION
20	INSTALLATION
22	NEW DEVELOPMENTS
23	ADVANTAGES

A woman is seen inside a glass-enclosed vertical steam shower, which is integrated into a modern kitchen. The shower is a tall, cylindrical unit with a glass door and a black frame. The kitchen features a white countertop, a stainless steel refrigerator, and open shelving with various kitchen items. The background shows a bright, open-plan living area with a large arched window and a wooden ceiling with exposed beams.

**BIG IDEAS
ARE ONES THAT
REVOLUTIONIZE
THE WORLD**

Human beings have always asked themselves how to take things further. The answer lies within ourselves: **by innovating.**

In 2002, in Miami, USA, **Pneumatic Vacuum Elevators®** was born. A company with a clear vision, **to create a new concept for a lift** that is simple, functional and aesthetically pleasing and that improves quality of life in homes all around the world: the **PVE pneumatic vacuum lift.**

It's a solution that has revolutionised the industry thanks to its **Vacuum Technology®** and its design.

It's such a **simple lift to install just like any other electronic household appliance** and requires a **minimal amount of space.**

Customizable and efficient, it adapts to any space, improving quality of life and standing out as a **work of art.**



AN INNOVATIVE SYSTEM

PVE lifts are the only ones in the world that work by using one of the most abundant natural resources: air.

What advantages does the Vacuum Technology® offer?

Its innovative design optimizes the use of space, **maximizing the cabin's useful interior** and doing away with the need for a machine room.

Installation is possible without the need for a pit or building work. It's the only lift that's installed **directly onto your home's existing floor.**

Installed in as little as **two to three days**, it's the **quickest installation on the market.**

Light and with no limitations, it's possible for it to be installed on upper floors and for it to reach anything up to **five stops or 15 metres in distance.**

It's available in **three different sizes** with a passenger capacity of **one, two and three**, respectively.





The pneumatic lift is a self-supporting circular structure that is installed directly onto the floor of the home.

Unlike traditional lifts, the pneumatic lift is self-supporting and self-contained.

Consisting of three main sections:

Exterior cylinder, fully panoramic

Car, that travels on the inside and transports passengers

Vacuum system, contains the suction motor. It is available in different formats and sizes to fit any kind of space.

System of operation of the vacuum lift

1. During the ascent, the system extracts air, creating a vacuum that makes the car go upwards.

2. For the descent, the intake of air is controlled, causing the car to move downwards smoothly without consuming electricity.

The Vacuum Technology® simplifies the operation and reduces wear and tear of components. A smooth, safe, reliable and durable system.

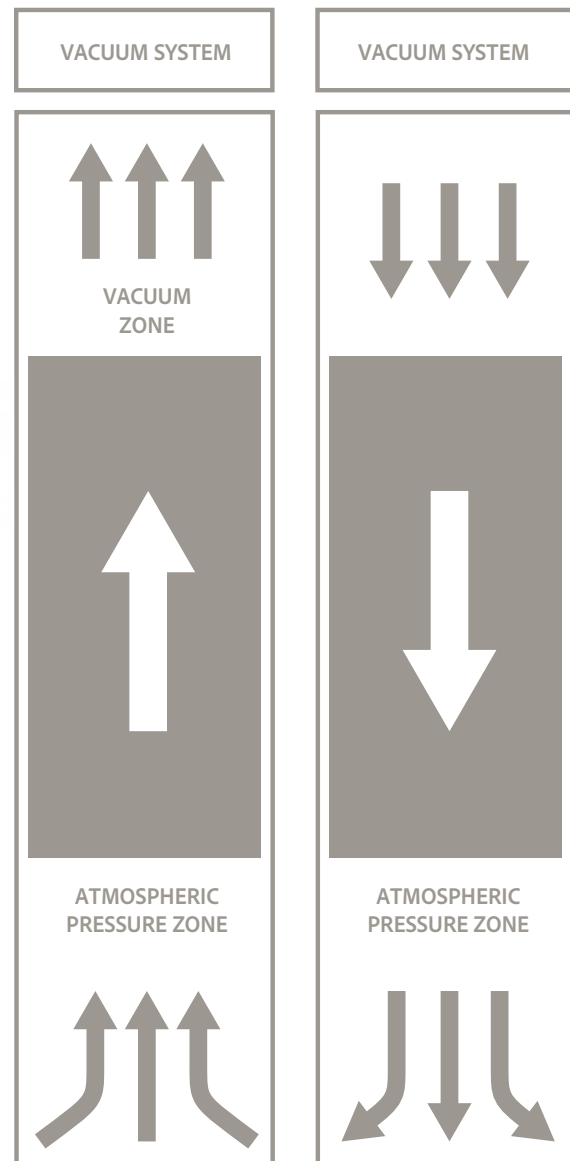





DESIGN

At PVE, we view the manufacture of lifts as an **art** form. We have created models in which design and technology go together to make the perfect combination, which is reflected in each and every one of our products.

Every detail of our **PVE lifts** has been designed with the aim and focus of offering a solution to the habitability and installation problems that are encountered in **single-family homes and duplex apartments**.

A versatile solution that fits into even the tightest of spaces, installing it **requires no complicated construction works**.

A revolutionary **all-in-one** design, it comprises a self-supporting structure with the motor built in and a completely transparent **360° panoramic car**.



SAFETY

PVE pneumatic vacuum lifts are approved by the prestigious **Liftinstituut**, the world's leading lift certification organization.

Holding **US and European Certifications**, PVE maintains the highest safety rating in home lifts, meeting if not exceeding all safety requirements.



REMOVE THE BARRIERS IN YOUR HOME

WELL-BEING

We are committed to excellence and innovation and we strive for your well-being, advising you on your project to offer you the best option that ensures full accessibility in your home.

Our goal is to provide the best quality of life for all members of the family.



**SMALL ON THE
OUTSIDE BIG ON
THE INSIDE**

Image courtesy of
www.heartlandstairways.com
manufacturer of spiral staircases

MODELS

PVE30

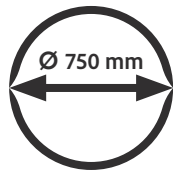

PVE37

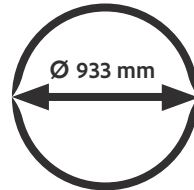

PVE52

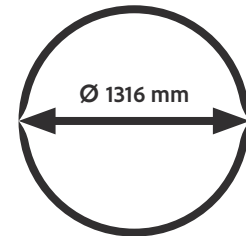

General	PVE30	PVE37	PVE52
Maximum load (kg)	159	205	238
Speed	<0.15m/s	<0.15m/s	<0.15m/s
Number of stops	2 to 5	2 to 5	2 to 5
Maximum distance (m)	15	15	15
Car			
Inside diameter (mm)	638	821	1210
Doorway width (mm)	505	517	813
One-touch automatic pulse	Yes	Yes	Yes
Accessible in a wheelchair	No	Yes, with a reduced-width wheelchair	Yes
Doors			
Available entrances	0°	0°, 90°, 270° and 180°	0° and 180°
Possibility of an automatic door	No	Yes	Yes
Safety			
Power failure automatic descent	Yes	Yes	Yes
Alarm button / safety telephone	Yes	Yes	Yes
Electricity			
Supply	220V / 20A	220V/25A	220V/32A
Power	3kW	5kW	6kW
Installation requirements			
Perforation diameter (mm)	810	990	1389
Minimum height on upper floor (mm)	2450	2450	2450

ALL OUR MODELS INCLUDE:

Telephone, LED Lighting, Automatic Ventilation
 CE marking according to Machinery Directive 2006/42/EC
 ISO 9001

Two-year guarantee with extension options

We are aware that every home is unique and we understand that you might want to choose every detail so that your PVE pneumatic lift can be adapted to and aesthetically fit in with the characteristics and decorations of your home.

For this reason, we offer a customization range that allows you to choose among a wide variety of colours and finishes.

STRUCTURE COLOURS

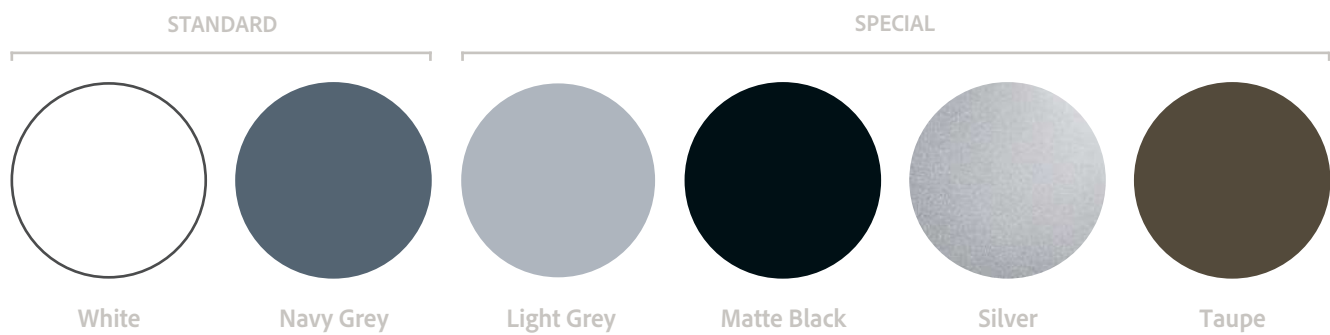

FLOOR OF THE CABIN

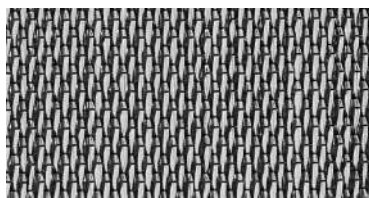

Metallic



Black

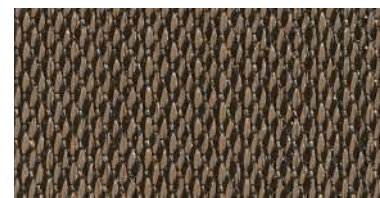

Golden brown

High-durability PVE vinyl carpet

CABIN CEILING FINISHES

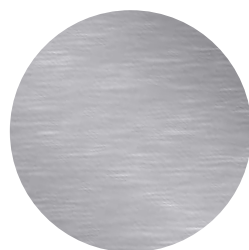

Brushed Aluminium

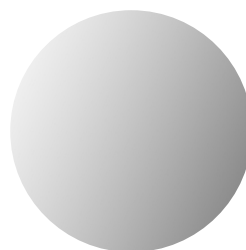

Mirror

**Talk to your Výtahy Praha sales representative for special off-catalogue customisations of colour and finishes.*

A LIFT THAT SHINES IN ITS OWN RIGHT

The one thing that matters to us is EVERYTHING. To be involved in every detail, day after day, establishing PVE as the very essence of a job well done.

We live in an ever-changing world and the best way for us to adapt is by evolving with it through continuous innovation, both in our products and in our services.

A photograph of a modern glass elevator installed in a rustic, multi-level home. The elevator is a sleek, cylindrical glass structure with a dark metal frame, positioned vertically in the center. To the left is a thick, rough-hewn stone wall with a small, square, black metal light fixture. To the right, a wooden staircase with a dark metal railing and decorative finials leads up. The ceiling features large, dark wooden beams, and the overall atmosphere is warm and traditional. The text "THE INCREDIBLE DESIGN THAT ADAPTS TO YOUR HOME" is overlaid in white, bold, sans-serif font in the lower-left quadrant.

**THE INCREDIBLE DESIGN
THAT ADAPTS TO YOUR
HOME**

HEAD OR SPLIT

Depending on the available height in your home, we have different installation options available. The total height of the cylinder will vary depending on the configuration. The top floor cylinder and roof finish is optional, please talk to your Výtahy Praha sales representative.

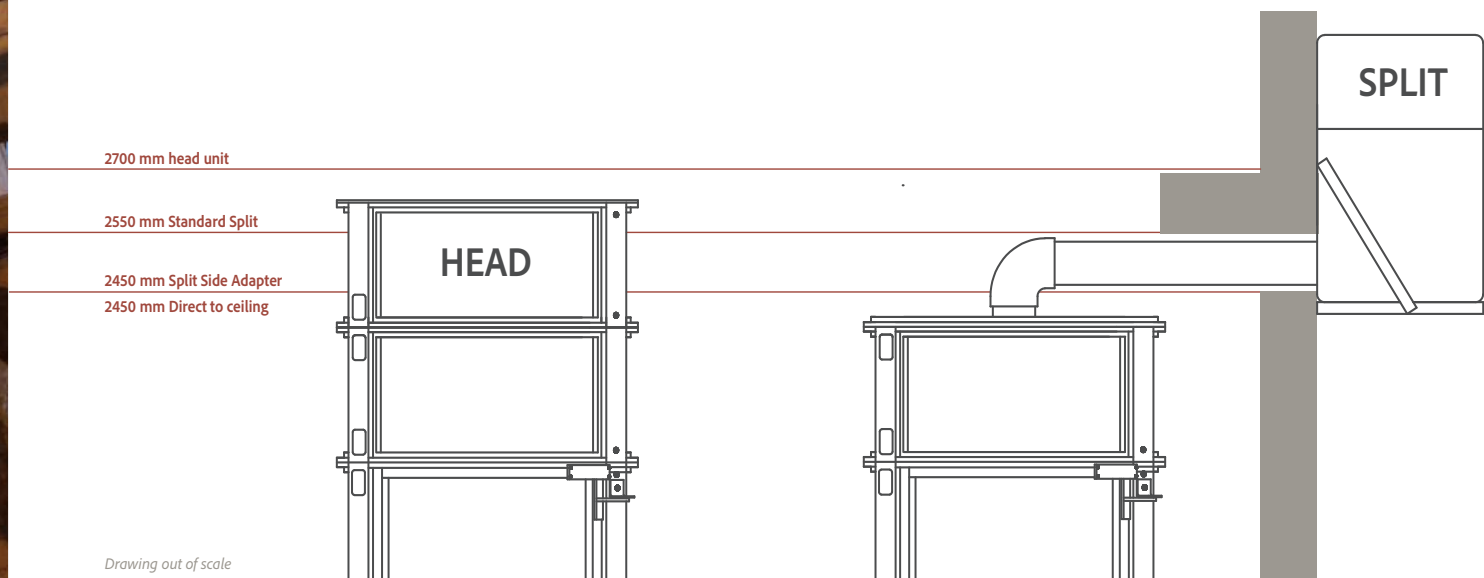

HEAD CONFIGURATION

This is a more aesthetically pleasing and simpler solution, in which the vacuum system is located directly at the top of the upper-floor module.

It's the simplest solution in terms of installation. It simply needs to be plugged in to the 220v mains.

MINIMUM HEIGHT ON THE UPPER FLOOR

2700 mm

SPLIT CONFIGURATION

This configuration allows for the vacuum system to be positioned anywhere in the home, by connecting piping with Ø110-mm PVC tubes to the lift.

The main advantage is that it reduces the minimum height required on the top floor and it takes away the sound of the vacuum system.

We offer four different installation options depending on the available height:

- Standard Split configuration with 90° elbow
- Fake Head configuration
- Split Side Adapter configuration
- Vertical Direct Split configuration

You can find the options in more detail on the next page.

SPLIT

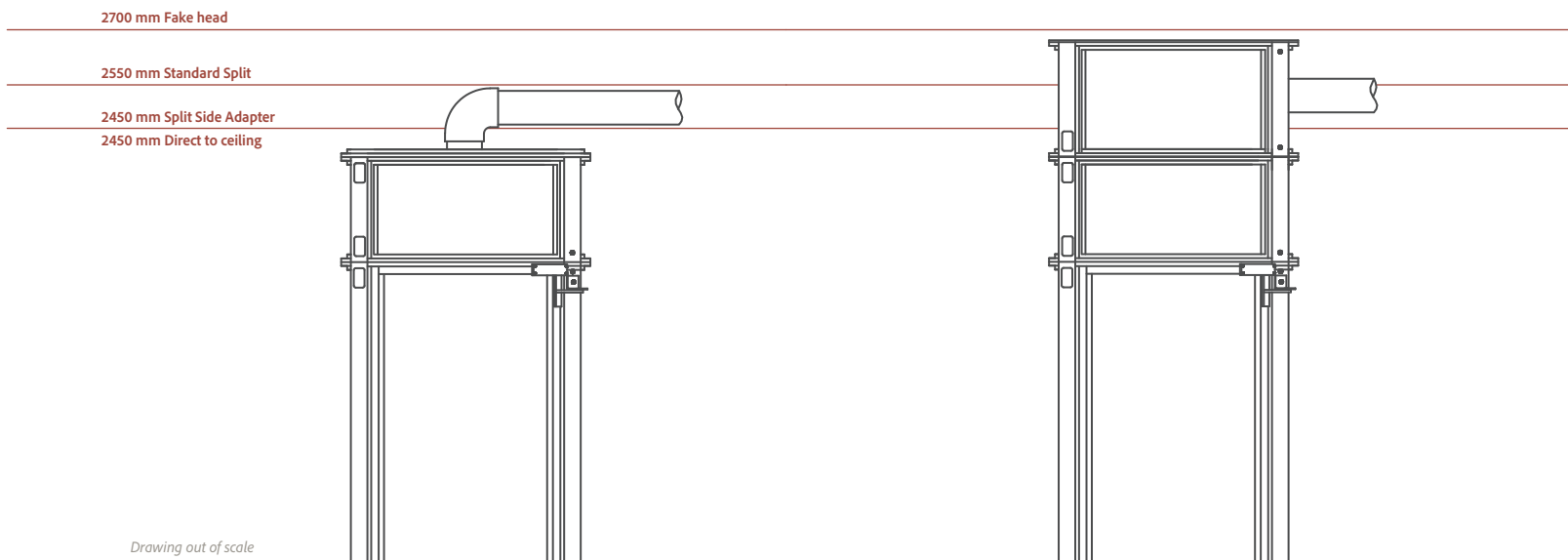

STANDARD SPLIT

Standard installation of the split configuration, making use of elbow joints for joining the tubes and the top of the cylinder

The electrical control panel needs to be located in interior environments.

ADVANTAGES

Reduction of noise in relation to the head configuration

Customizable positioning of the vacuum system.

MINIMUM HEIGHT ON UPPER FLOOR

2550 mm

FAKE HEAD

Similar installation to the Standard Split but covered with an extension of the cylinder that conceals the PVC tubes' exit

It allows for the installation of the electrical control panel inside it, avoiding the need for wiring and supplementary works.

ADVANTAGES

Better aesthetic finish

Reduction of sound in relation to the head configuration.

MINIMUM HEIGHT ON UPPER FLOOR

2700 mm

OPTIONS

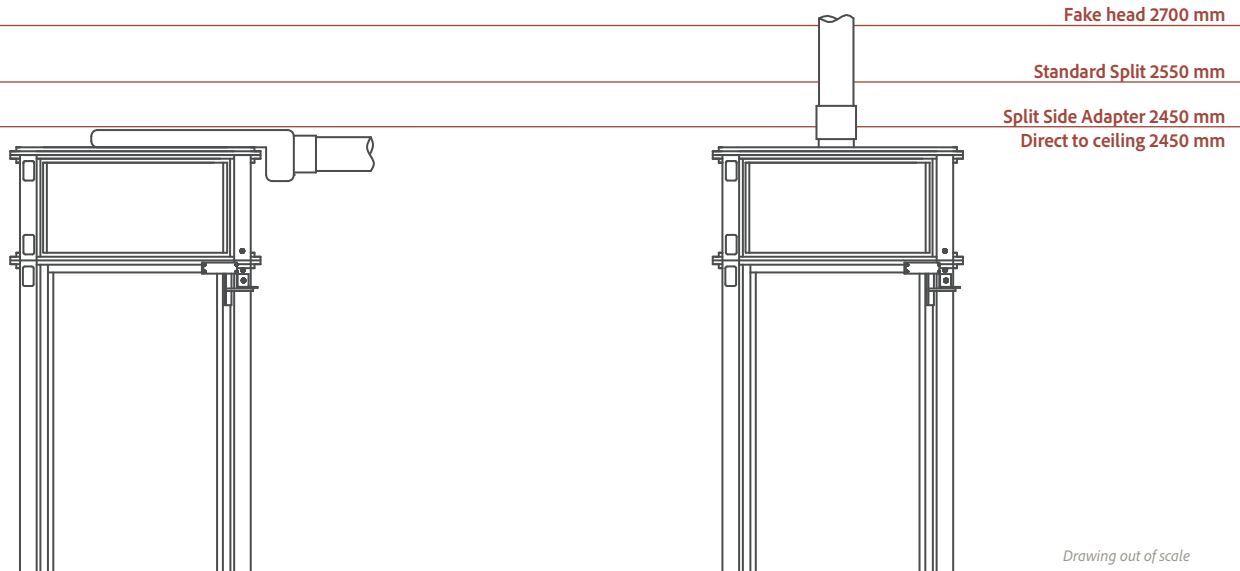

Drawing out of scale

SPLIT SIDE ADAPTER

An installation piece that allows the PVC tubes to be connected horizontally, avoiding the need for elbow joints and reducing the minimum height required

The electrical control panel must be located in interior environments. Pipes are visible.

ADVANTAGES

Minimal overhead distance (free height on the upper floor)

Reduction of sound in relation to the head configuration

Customizable positioning of the vacuum system and electrical control panel.

MINIMUM HEIGHT ON UPPER FLOOR

2450 mm

DIRECT VERTICAL

Installation of PVC tube(s) in a direct vertical position through the ceiling. As such, it's only a viable option if the home allows for a hole to be made in the ceiling.

The electrical control panel must be located in interior environments. Pipes are visible.

ADVANTAGES

Minimal overhead distance (free height on the upper floor)

Reduction of sound in relation to the head configuration

Customizable positioning of the vacuum system and electrical control panel

MINIMUM HEIGHT ON UPPER FLOOR

2450 mm

BALCONY WITH WALKWAY

EMBEDDED BALCONY

THROUGH FLOOR

Steel Cord
Walkway

BALCONY METHOD

When the lift is installed in an open space, a double-height area or a stairwell where it's not necessary to create a hole

It's characterised by its simplicity and speed of installation.

It's necessary to install a **platform for getting out or a walkway**, the purpose of which being to cover the space between the lift and the floor and to provide stability for attaching the structure on each floor by means of a **steel cord** used as a belt

TYPES OF WALKWAY

Different configurations for a transitional platform or walkway

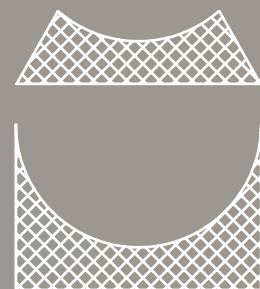

INSTALLATION OPTIONS

THROUGH FLOOR

A hole is made on each floor with a finished diameter 50 mm greater than the exterior diameter of the lift. In lifts with three, four or five stops, the holes must be aligned.

Drawing out of scale

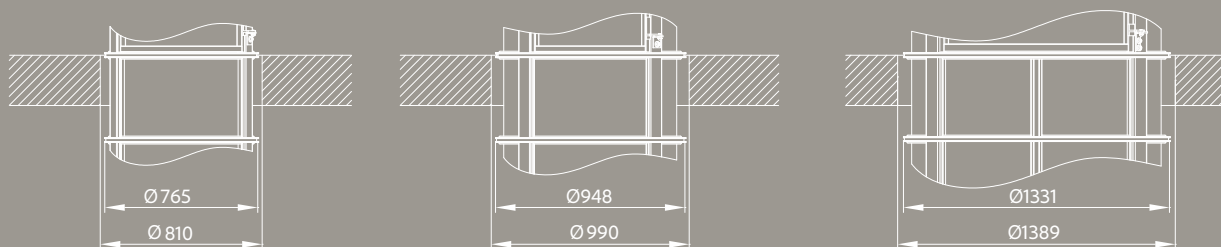

Minimum diameters for holes in through-floor installations.

BALCONY PLANS

The transitional platform is a connecting piece between the lift and the floor. The main purpose is to prevent any space between the circular shaft and floor, and creating a nice finish between the finished floor and lift. The finish work can be done in a number of different configurations and styles.

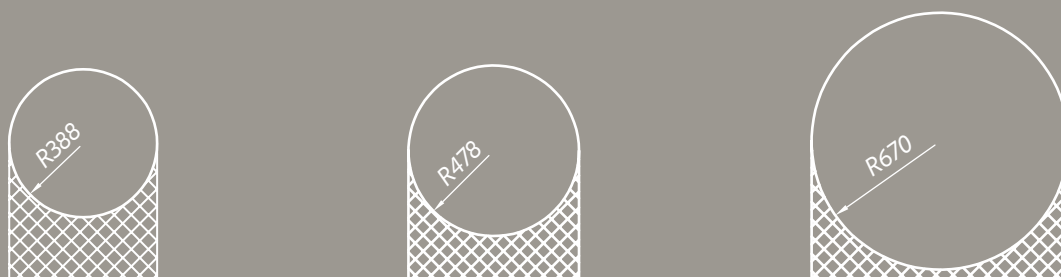



NEW DEVELOPMENTS

SMART HOME

100% compatible with Google Home and Alexa devices, allowing voice control.



INSTALLATION IN BOATS AND YACHTS

Thanks to the lightness of the materials used, the simplicity of the installation and the pitless design, PVE lifts are the best option for installation in your yacht or boat.

COMMITTING TO SUSTAINABILITY

At PVE, we care about the environment and we're committed to sustainability. As a result, we have developed an exclusive PV solar-power supply system for your lift.



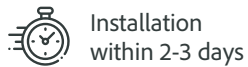
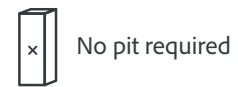
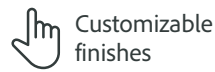
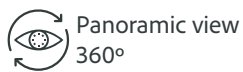
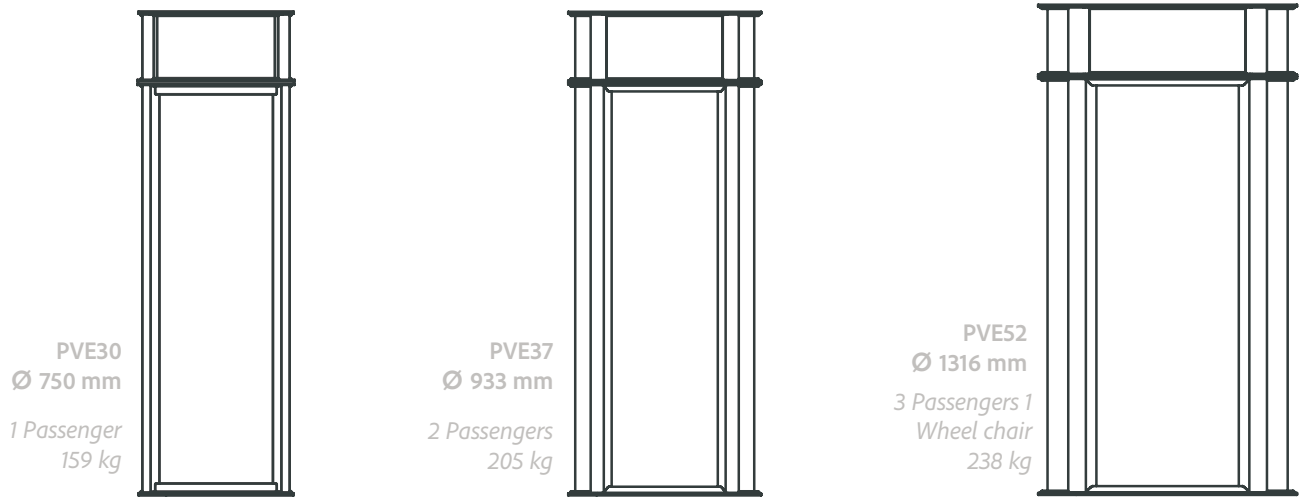

All of our lifts have **CE certification** according to the **European Machinery Directive 2006/42/EC**.

In 2019, PVE obtained the **ISO 9001 certification**, with a focus on an ongoing improvement and quality assurance process.

The winner for two years in a row (2018 and 2019) of the **Ellies Awards prize as best manufacturer of single-family lifts in the world**, awarded by the industry's most influential professional media outlet, the **Elevator World** magazine.





**Czech Republic
Slovak Republic**

Novolhotská 2622 190
16 Praha 21
Česká republika
(+420) 608 714 667
www.vytahypraha.com
info@vytahypraha.cz

Europe

C/ Primavera 19 28850,
Madrid
Spain
(+34) 918 867 539
www.pve-lifts.com
info@ascensoresneumaticos.eu

USA

12602 NW 115th Avenue
33178, Miami, FL
USA
(+1) 305 884 1091
www.vacumelevators.com
info@vacumelevators.com